

NOTES:
 EEDO,WAKEUP internal pull low (ie,NC)

EEDO (P65)	WAKEUP (P97)	Data Length
pull high	(NC)	32 bits
(NC)	(NC)	16 bits
(NC)	pull high	8 bits

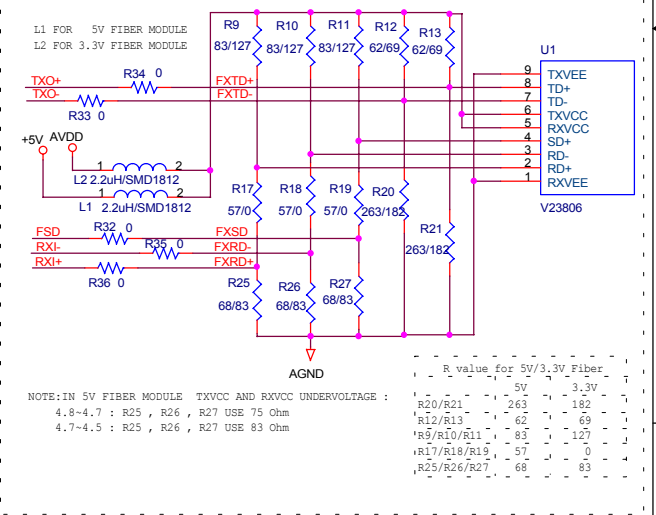
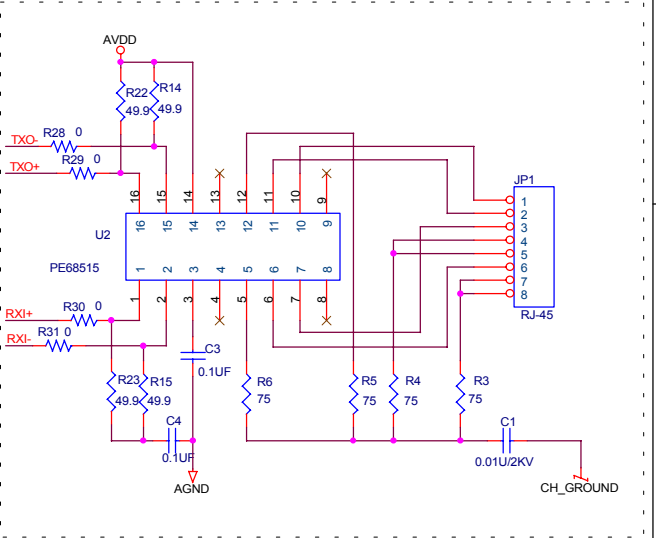

NOTE: FOR 32-BIT EMBEDDED SYSTEM APPLICATION REFERENCE ONLY