

THIS CIRCUIT IS JUST FOR REFERENCE

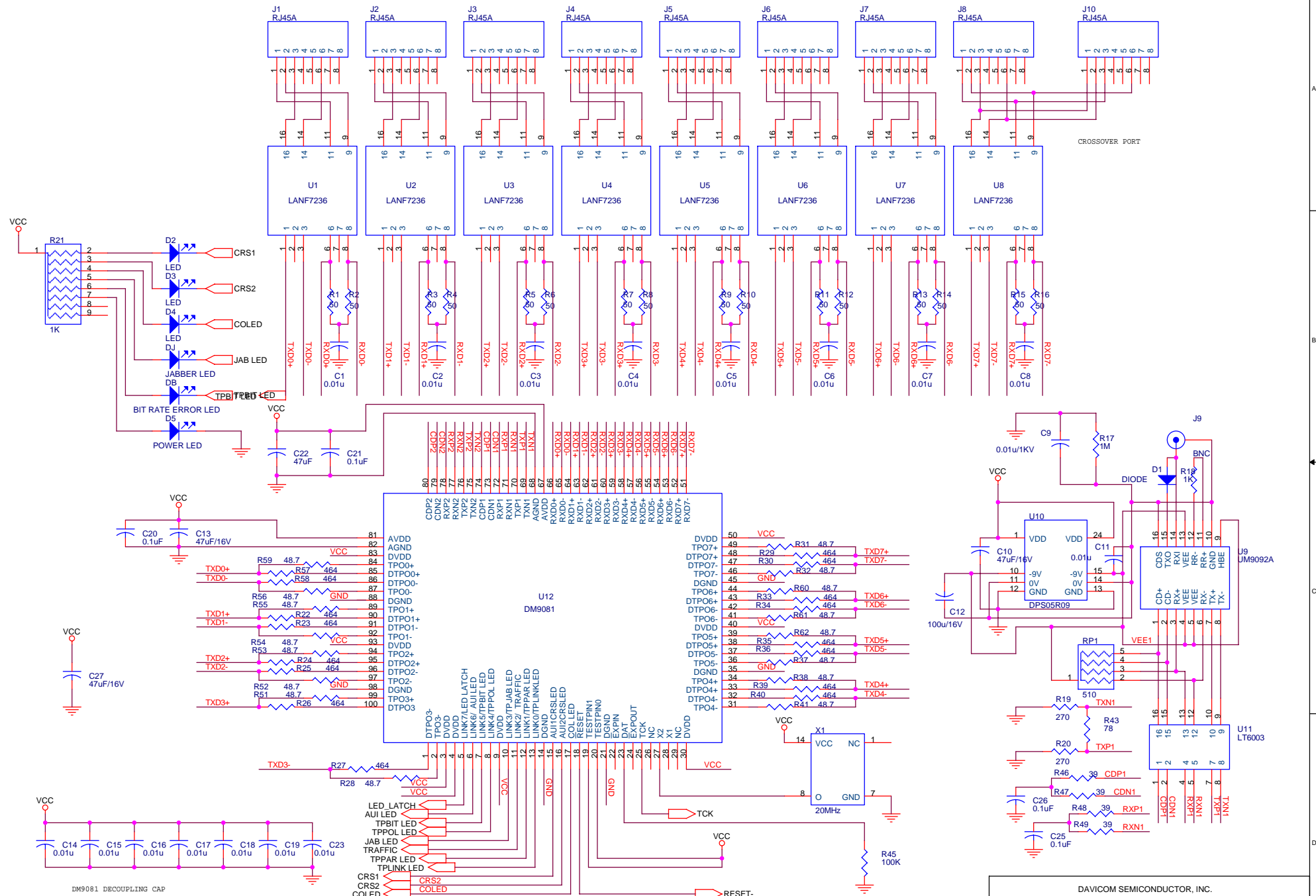

DAVICOM SEMICONDUCTOR, INC.		
Title 8 PORT HUB (NORMAL MODE)		
Size Custom	Document Number DM9081 CONTROLLER	Rev 1.0
Date: Thursday, September 14, 2000	Sheet	1 of 3

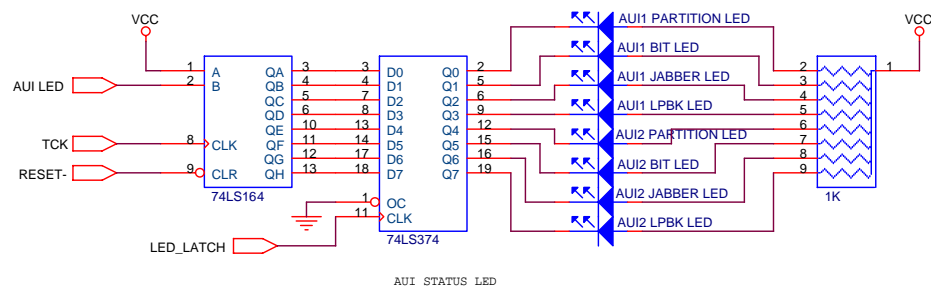
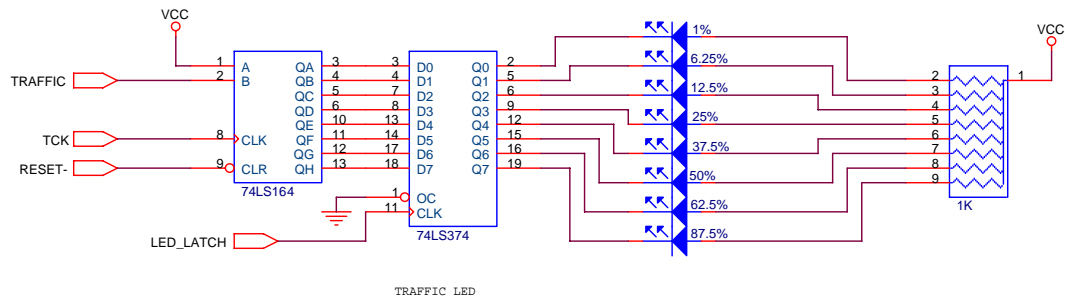
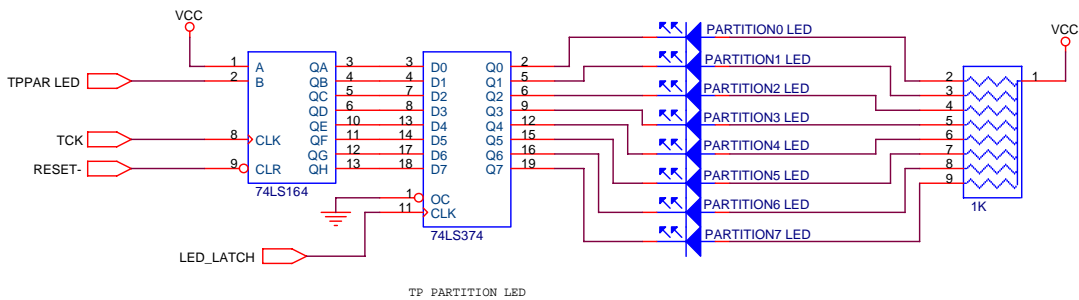
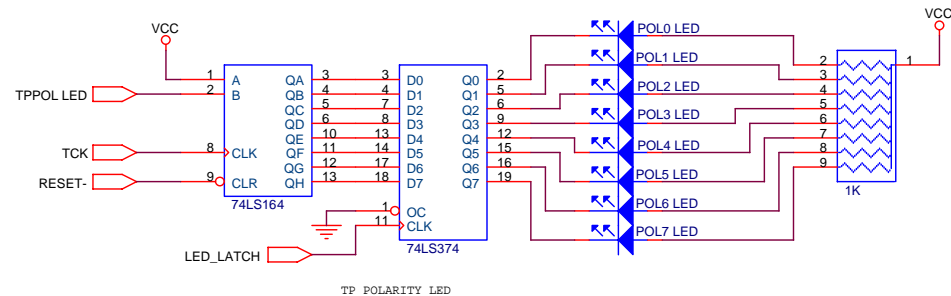
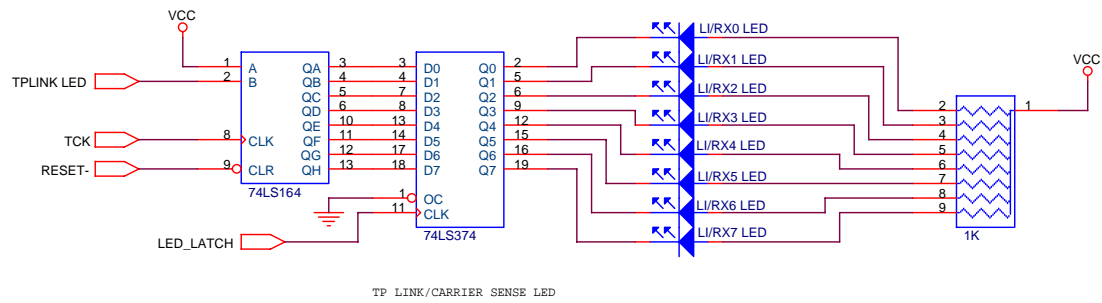

DESINGER CAN CHOOSE LED FUNCTION TO IMPLEMENT YOUR HUB.

THIS CIRCUIT IS JUST FOR REFERENCE

DAVICOM SEMICONDUCTOR, INC.		
Title 8 PORT HUB (NORMAL MODE)		
Size B	Document Number DM9081 LED DISPLAY	Rev 1.0
Date: Monday, April 24, 2000	Sheet 3	of 3