

DM5865

- ~ 4 Channel 720H Video Decoder
- ~ Pin Compatible with TW2865

DAVICOM Semiconductor, Inc.

| | | |
|------------|-----------------------------|--------------|
| Title | | |
| DM5865_REF | | |
| Size | Document Number | Rev |
| A4 | DM5865 | 1.0 |
| Date: | Thursday, November 07, 2013 | Sheet 1 of 3 |

DM5865

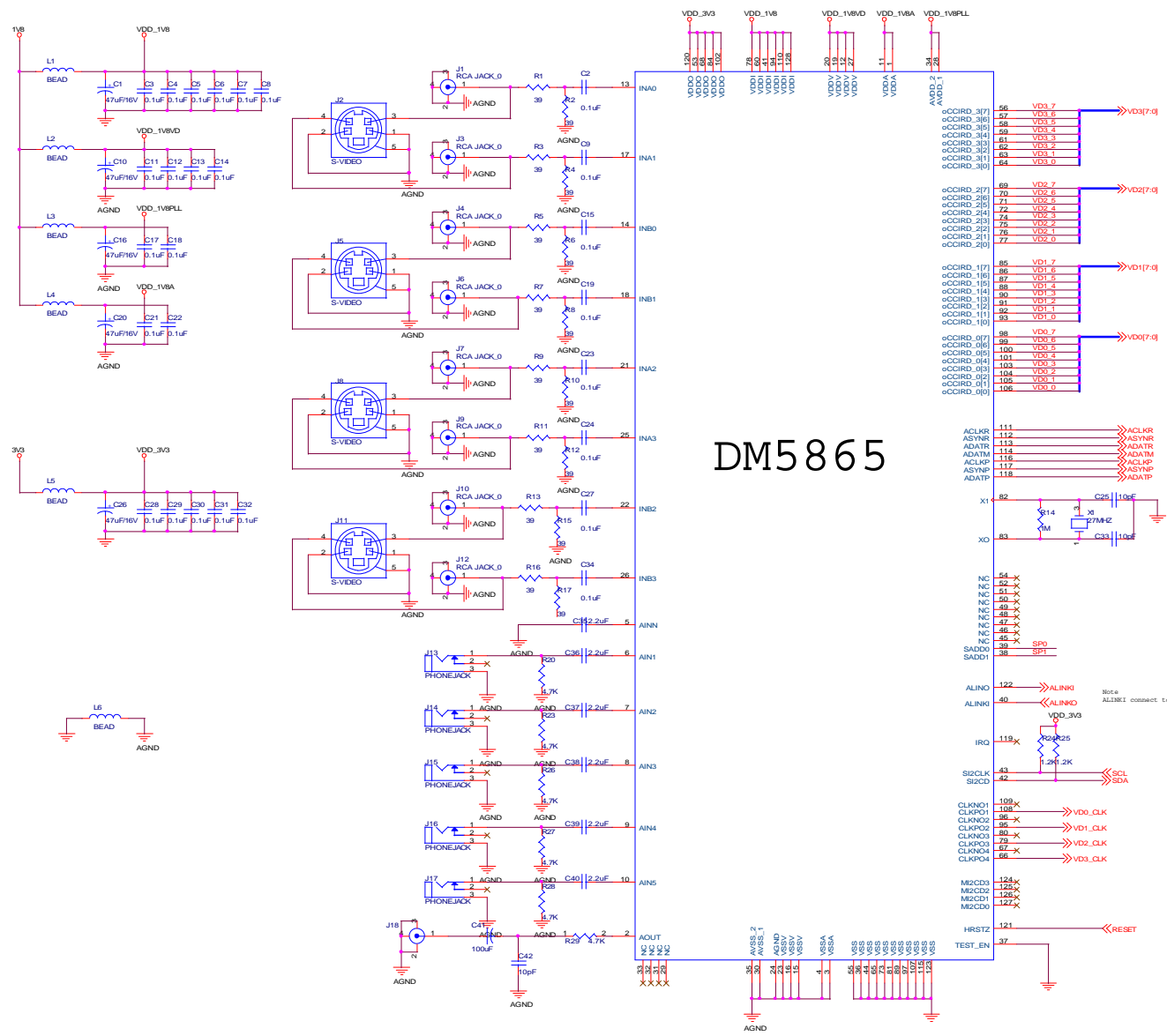

- Note
1. VD0[7:0] & VD0_CLK走線盡量等長
 2. VD1[7:0] & VD1_CLK走線盡量等長
 3. VD2[7:0] & VD2_CLK走線盡量等長
 4. VD3[7:0] & VD3_CLK走線盡量等長

| | 27MHz | TDM54 | TDM108 |
|---------------|-------|-------|--------|
| oCCIRD_0[7:0] | V | V | V |
| oCCIRD_1[7:0] | V | V | |
| oCCIRD_2[7:0] | V | | |
| oCCIRD_3[7:0] | V | | |

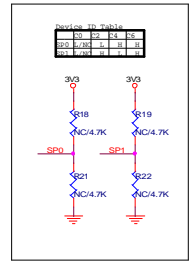

| VER | DATE | ENGINEER | NOTE |
|-----|------------|-------------|--------------------|
| 1.0 | 07/11/2013 | CONNOR HONG | NEW CIRCUIT DM5865 |

DAVICOM Semiconductor, Inc.

| | | |
|--|----------------------------|------------|
| Title | | |
| DM5865_REF | | |
| Size A4 | Document Number HISTORY | Rev 1.0 |
| Date: Thursday, November 07, 2013 Sheet 3 of 3 | | |